



EN: Stackable barstool with double injection molded polypropylene shell and Ø14 mm steel tube frame

IT: Sgabello impilabile con scocca in polipropilene stampato a bi-iniezione e struttura in tubo d'acciaio Ø14 mm

DE: Stapelbarer Hocker mit Sitzschale aus doppelt spritzgegossenem Polypropylen und einer Struktur aus Stahlrohr Ø14 mm

FR: Tabouret empilable avec coque en polypropylène moulé par double-injection et structure en tube d'acier Ø14 mm

ES: Taburete apilable con carcasa de polipropileno moldeado por bi-inyección y estructura en tubo de acero Ø14 mm

mm - in

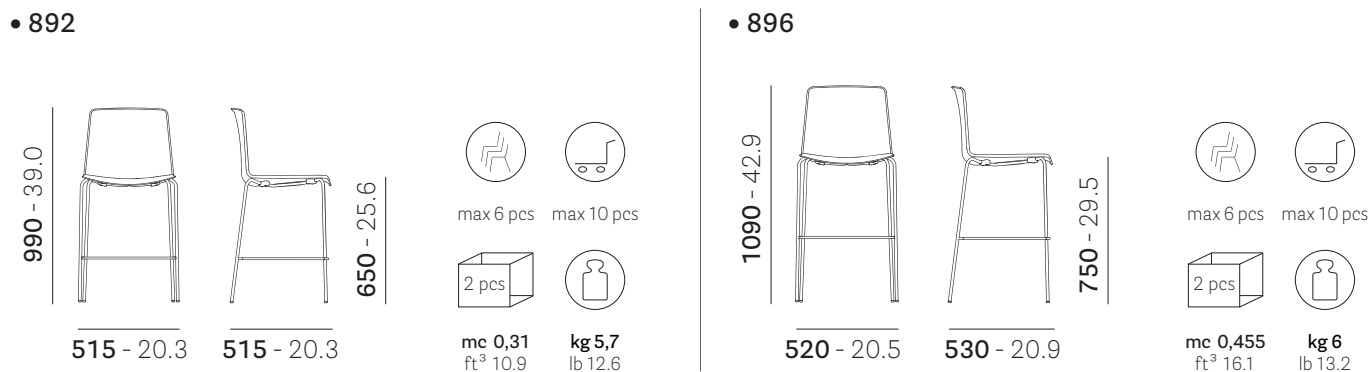

MATERIALS

Materiali
Materialien
Matériaux
Materiales

• SHELL - SCOCCA - SCHALE - COQUE - CARCASA

EN: Glass-fibre reinforced polypropylene shell, antistatic and anti-UV

IT: Scocca in polipropilene caricato con fibra di vetro, antistatica e anti-UV

DE: Gehäuse aus glasfaserverstärktem Polypropylen, antistatisch und UV-beständig

FR: Coque en polypropylène renforcée de fibres de verre, antistatique et anti-UV

ES: Carcasa de polipropileno reforzado con fibra de vidrio, antiestática y anti-UV

TECHNOLOGY - TECNOLOGIA - TECHNOLOGIE - TECHNOLOGIE - TECNOLOGÍA

EN: Double Injection moulding

IT: Stampaggio a bi-iniezione

DE: Doppelt Injektionsdruck-Guss

FR: Moulage sous double injection

ES: Molde de bi-inyección

COLOURS - COLORI - FARBEN - COLORIS - COLORES

EN: Hammered front surface, glossy back surface

IT: Superficie anteriore goffrata, superficie posteriore lucida

DE: Geprägte Vorderseite, glänzende Rückseite

FR: Surface avant gaufrée, surface arrière brillante

ES: Superficie frontal microtexturada, superficie trasera brillante

DESIGN
Marc Sadler

EN: One colour

IT: Monocolore
DE: Einfarbig
FR: Monocouleur
ES: Un sólo color



EN: Bicolour with white inner shell

IT: Bicolore con scocca interna sempre bianca
DE: Zweifarbig mit weißer Innenschal
FR: Bicolore avec coque intérieure blanche
ES: Bicolor con carcasa interior blanca



• **FRAME - TELAIO - STRUKTUR - STRUCTURE - ARMAZÓN**

EN: Steel frame, tube Ø14 mm

IT: Struttura in acciaio, tubo Ø14 mm
DE: Struktur aus Edelstahl Rohr Ø14 mm
FR: Structure en acier, tube Ø14 mm
ES: Estructura en acero, tubo Ø14 mm

FRAME FINISH - FINITURA TELAIO - AUSFÜHRUNG DES GESTELL - FINITIONS STRUCTURE - ACABADO ARMAZÓN

EN: Powder coating

IT: Verniciato con polvere
DE: Pulverbeschichtet
FR: Époxy à poudre
ES: Barnizado con polvo



EN: For full range of color available see finishing legend on the website

IT: Per tutta la gamma di colori disponibili vedere legenda finiture sul sito web

EN: Chromed

IT: Cromato
DE: Verchromt
FR: Chromé
ES: Cromado



• **FEET - PIEDINI - GLEITER - PATINS - TACOS**



EN: White or black technopolymer, on request feet with felt /00 suitable for delicate and sensitive floors (wood, ceramic, marble)

IT: Tecnopolimero bianco o nero, a richiesta piedini con feltrino /00 adatti per pavimenti delicati e sensibili (legno, ceramica, marmo)
DE: Weißes oder schwarzes Technopolymer, auf Anfrage Füße mit Filz /00 geeignet für empfindliche und sensible Böden (Holz, Keramik, Marmor)
FR: Technopolymère blanc ou noir, sur demande pieds avec feutre /00 adapté aux sols délicats et sensibles (bois, céramique, marbre)
ES: Tecnopolímero blanco o negro, a petición pies con fieltro /00 adecuado para suelos delicados y sensibles (madera, cerámica, mármol)

Reproduction of this document is strictly prohibited without prior written authorisation from Pedrali SpA. Sizes, weights and finishes may change without previous notice. È vietata la riproduzione del seguente documento senza previa autorizzazione scritta da parte di Pedrali SpA. Dimensioni, pesi e finiture possono variare senza alcun preavviso.

ST_TWEET_892_896_2025.0

DESIGN
Marc Sadler

<p>ACCESSORIES Accessori Zubehörteile Accessoires Accesorios</p>	<p>code 775.100</p> <p>EN: Trolley IT: Carrello DE: Wagen FR: Chariot ES: Carrito</p>																														
<p>REGULATIONS AND CERTIFICATES Normative e Certificazioni Bestimmungen und Zertifikat Normatives et certifications Normativas y certificados</p>	<ul style="list-style-type: none"> <p>PRODUCT CERTIFICATIONS - CERTIFICAZIONI DI PRODOTTO - PRODUKTZERTIFIZIERUNGEN - CERTIFICATIONS DE PRODUITS - CERTIFICACIONES DE PRODUCTO</p> <p>EN: Product tested in accordance with UL 2821 test method to show compliance to emission limits on UL 2818. Section 7.1 and 7.2 IT: Prodotto testato secondo il metodo UL 2821 test per dimostrare la conformità ai limiti di emissione della UL 2818. Sezione 7.1 e 7.2</p> <div style="display: flex; justify-content: space-around;">   </div> <p>RESISTANCE TEST - TEST DI RESISTENZA - TEST ZUR BELASTBARKEIT - TEST DE RÉSISTANCE - PRUEBA DE RESISTENCIA</p> <p>EN 1728:2012, 6.4 - EN 16139:2013, L2 EN 1728:2012, 6.5 - EN 16139:2013, L2 EN 1728:2012, 6.17 - EN 16139:2013, L2</p> <p>ENVIRONMENTAL IMPACT - IMPATTO AMBIENTALE - UMWELTBELASTUNG - IMPACT DUR L'ENVIRONNEMENT - IMPACTO AMBIENTAL</p> <table border="1" data-bbox="370 1176 1436 1556"> <thead> <tr> <th>MATERIAL Materiale</th> <th>Kg WEIGHT Peso</th> <th>% TOTAL ITEM Totale articolo</th> <th>MATERIAL RECYCLABILITY Riciclabilità del materiale</th> <th>% MINIMUM RECYCLED AT ORIGIN Minima riciclato all'origine</th> <th>% RECYCLABLE END OF PRODUCT LIFE Riciclabile fine vita prodotto</th> </tr> </thead> <tbody> <tr> <td>Steel Acciaio</td> <td>3,29</td> <td>54,74</td> <td>YES</td> <td>33,2</td> <td>100</td> </tr> <tr> <td>Polypropylene Polipropilene</td> <td>2,7</td> <td>44,93</td> <td>YES</td> <td>0</td> <td>100</td> </tr> <tr> <td>Polyethylene Polietilene</td> <td>0,02</td> <td>0,33</td> <td>YES</td> <td>0</td> <td>100</td> </tr> <tr> <td>TOTAL TOTALE</td> <td>6 Kg</td> <td>--</td> <td>--</td> <td>18,2 %</td> <td>100%</td> </tr> </tbody> </table> <p>EN: Percentages referred to 896 IT: Percentuali riferite al 896</p> 	MATERIAL Materiale	Kg WEIGHT Peso	% TOTAL ITEM Totale articolo	MATERIAL RECYCLABILITY Riciclabilità del materiale	% MINIMUM RECYCLED AT ORIGIN Minima riciclato all'origine	% RECYCLABLE END OF PRODUCT LIFE Riciclabile fine vita prodotto	Steel Acciaio	3,29	54,74	YES	33,2	100	Polypropylene Polipropilene	2,7	44,93	YES	0	100	Polyethylene Polietilene	0,02	0,33	YES	0	100	TOTAL TOTALE	6 Kg	--	--	18,2 %	100%
MATERIAL Materiale	Kg WEIGHT Peso	% TOTAL ITEM Totale articolo	MATERIAL RECYCLABILITY Riciclabilità del materiale	% MINIMUM RECYCLED AT ORIGIN Minima riciclato all'origine	% RECYCLABLE END OF PRODUCT LIFE Riciclabile fine vita prodotto																										
Steel Acciaio	3,29	54,74	YES	33,2	100																										
Polypropylene Polipropilene	2,7	44,93	YES	0	100																										
Polyethylene Polietilene	0,02	0,33	YES	0	100																										
TOTAL TOTALE	6 Kg	--	--	18,2 %	100%																										

Reproduction of this document is strictly prohibited without prior written authorisation from Pedrali SpA. Sizes, weights and finishes may change without previous notice.
 È vietata la riproduzione del seguente documento senza previa autorizzazione scritta da parte di Pedrali SpA. Dimensioni, pesi e finiture possono variare senza alcun preavviso.

ST_TWEET_892_896_2025.0